

TAB/TAB95 series

FULLY AUTOMATIC SMALL-SIZED VOLTAGE REGULATOR

Ac Automatic Voltage Regulator



TAB/TAB95 series (500VA-2000VA)

PRODUCT FEATURES

The product of this model is a 220V fully automatic small-sized voltage regulator, which is a portable LED digital display design. It is characterized by small size, light weight, high voltage regulation speed and no waveform distortion.

APPLICATION

It is widely used in various industries, small office equipment, refrigerator, electric fan, TV set, computer and other household appliances.

PRODUCTS SPECIFICATION



MODEL	TAB (500VA-2000VA)	TAB95 (500VA-2000VA)		
INPUT VOLTAGE	AC 130V-270V	AC 95V-270V		
OUTPUT VOLTAGE	AC 220V±10% 50/60Hz			
DELAY TIME	Short Delay:3-5sec Long Delay:3-7min			
PROTECTION	Over Voltage(246V±4V),Overload,High Temperature,Short Circuit			
POWER	500VA	1000VA	1500VA	2000VA
PRODUCT SIZE(CM)	37x12.5x7.7	37x12.5x7.7	39x14x9.3	39x14x9.3
PACKING SIZE(CM)	52x43x26.5	41.6x18.4x12.6	54x45x28.5	54x45x28.5
PCS/CARTON	6	6	6	6
N.W.(KGS)	10.3	13.3	17.5	20
G.W.(KGS)	12.3	15.3	19.5	21.9

FUNCTION DISPLAY

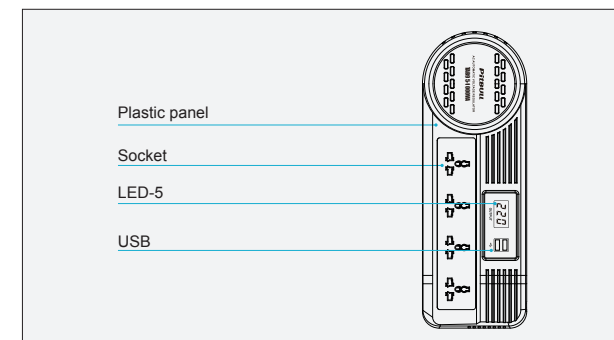

FRONT PANEL

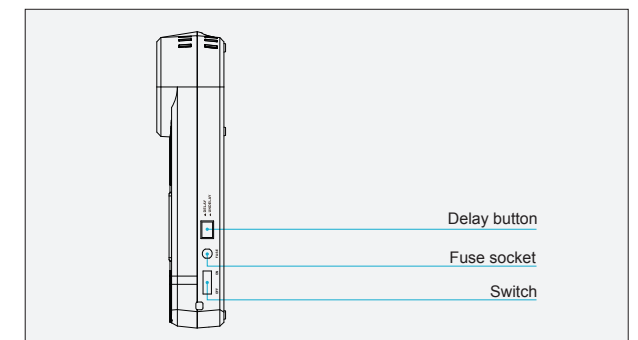

SIDE



Relay Control+Toroidal Transformer, Efficiency > 97%

MOD45/MOD60/MOD95 series (3000VA-15kVA)

PRODUCT FEATURES

The product of this model is a 220V fully automatic voltage regulator, both for desktop and wall mounted. With LED digital display design. It is characterized by stable work, high pressure regulation speed and wide voltage regulation range.

PRODUCTS SPECIFICATION



MODEL	MOD45-3000VA	MOD60-3000VA	MOD95-3000VA
INPUT VOLTAGE	AC 45V-270V	AC 60V-270V	AC 95V-270V
OUTPUT VOLTAGE	AC 220V±10% 50/60Hz		
DELAY TIME	Short Delay:3-5sec Long delay:3-7min		
PROTECTION	Over Voltage(246V±4V),Overload,High Temperature,Short Circuit		
POWER	3000VA		
PRODUCT SIZE(CM)	39x24.5x10		
PACKING SIZE(CM)	44x29.5x15.3		
PCS/CARTON	1		
N.W.(KGS)	11.3		
G.W.(KGS)	12		



MODEL	MOD45(5000VA-8000VA)	MOD60(5000VA-8000VA)	MOD95(5000VA-8000VA)
INPUT VOLTAGE	AC 45V-280V	AC 60V-280V	AC 95V-280V
OUTPUT VOLTAGE	AC 220V±10% 50/60Hz		
DELAY TIME	Short Delay:3-5sec Long delay:3-7min		
PROTECTION	Over Voltage(246V±4V),Overload,High Temperature,Short Circuit		
POWER	5000VA	8000VA	
PRODUCT SIZE(CM)	41x29.5x15	41x29.5x15	
PACKING SIZE(CM)	46x34.5x21	46x34.5x21	
PCS/CARTON	1	1	
N.W.(KGS)	15.7	20	
G.W.(KGS)	16.3	21.1	



APPLICATION

It is widely used in various industries, small office equipment, refrigerator, electric fan, computer, pump, air conditioner and other household appliances.

PRODUCTS SPECIFICATION



MODEL	MOD45(10kVA-15kVA)	MOD60(10kVA-15kVA)	MOD95(10kVA-15kVA)
INPUT VOLTAGE	AC 45V-280V	AC 60V-280V	AC 95V-280V
OUTPUT VOLTAGE	AC 220V±10% 50/60Hz		
DELAY TIME	Short Delay:3-5sec Long Delay:3-7min		
PROTECTION	Over Voltage(246V±4V),Overload,High Temperature,Short Circuit		
POWER	10kVA	12kVA	15kVA
PRODUCT SIZE(CM)	45x31.5x17	45x31.5x17	45x31.5x17
PACKING SIZE(CM)	51.8x38.5x23.7	51.8x38.5x23.7	51.8x38.5x23.7
PCS/CARTON	1	1	1
N.W.(KGS)	22.6	23	30.1
G.W.(KGS)	25.2	24.4	33.4

FUNCTION DISPLAY

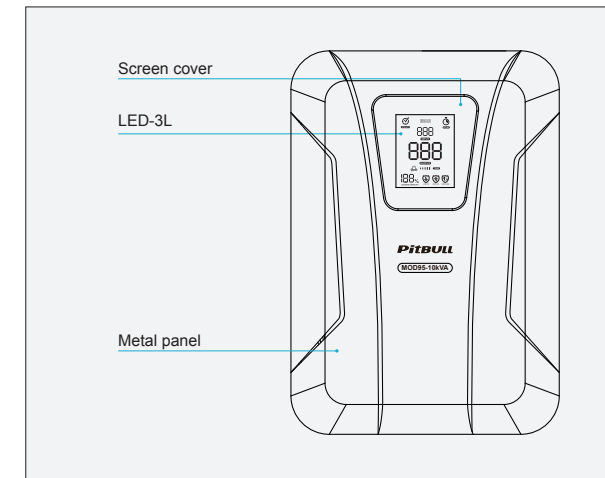

FRONT PANEL

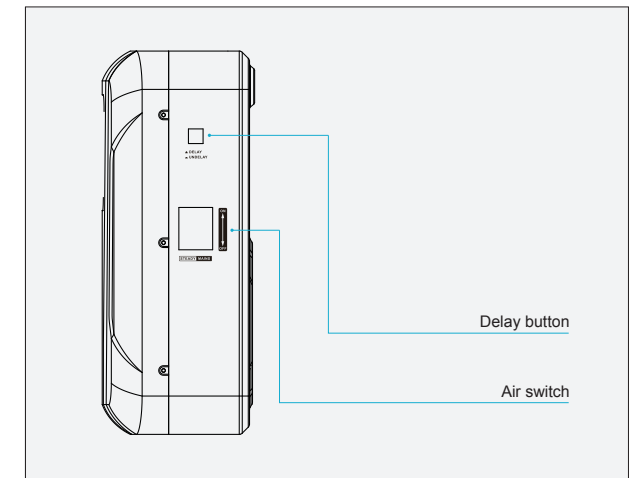

SIDE



Relay Control+Toroidal Transformer, Efficiency > 97%



Relay Control+Toroidal Transformer, Efficiency > 97%



MOD45/MOD60/MOD95 series (20kVA)

FUNCTION PRESENTATION



MODEL	MOD45-20kVA	MOD60-20kVA	MOD95-20kVA
INPUT VOLTAGE	AC 45V-280V	AC 60V-280V	AC 95V-280V
OUTPUT VOLTAGE	AC 220V±10% 50/60Hz		
DELAY TIME	Short Delay:3-5sec Long delay:3-7min		
PROTECTION	Over Voltage(246V±4V), Overload, High Temperature, Short Circuit		
POWER	20kVA		
PRODUCT SIZE(CM)	45x31.5x18		
PACKING SIZE(CM)	52x39x25.2		
PCS/CARTON	1		
N.W.(KGS)	35		
G.W.(KGS)	37		

FUNCTION PRESENTATION

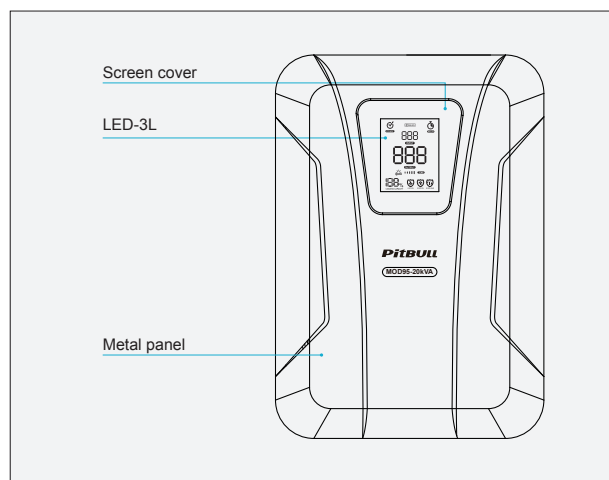

FRONT PANEL

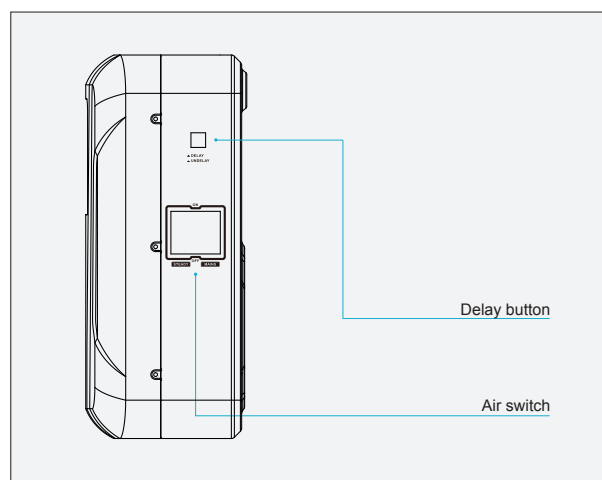

TOP



Relay Control+Toroidal Transformer, Efficiency >97%



TMQ/TMQ45/TMQ60/TMQ95 series (5000VA-15kVA)

PRODUCT FEATURES

The product of this model is a 220V fully automatic voltage regulator, with Wall-mounted design, the appearance is concise and generous. Display of LED digital design. it is characterized by stable work, high pressure regulation speed and wide voltage regulation range.

APPLICATION

Widely used in various industries, small office equipment and refrigerators, electric fans, air conditioning, television and other small appliances.

PRODUCTS SPECIFICATION



MODEL	TMQ(5kVA-15kVA)	TMQ45(5kVA-15kVA)	TMQ60(5kVA-15kVA)	TMQ95(5kVA-15kVA)
INPUT VOLTAGE	AC 130V-270V	AC 45V-280V	AC 60V-280V	AC 95V-280V
OUTPUT VOLTAGE	AC 220V±10% 50/60Hz			
DELAY TIME	Short Delay:3-5sec			
PROTECTION	Over Voltage(246V±4V),Overload,High Temperature,Short Circuit			
POWER	5000VA	10000VA	12000VA	15000VA
PRODUCT SIZE(CM)	44x32x21	44x32x21	44x32x21	44x32x21
PACKING SIZE(CM)	49.8x37x25.5	49.8x37x25.5	49.8x37x25.5	49.8x37x25.5
PCS/CARTON	1	1	1	1
N.W.(KGS)	16.5	21.7	23.2	24.5
G.W.(KGS)	17.8	23.3	24.5	26.4

FUNCTION DISPLAY

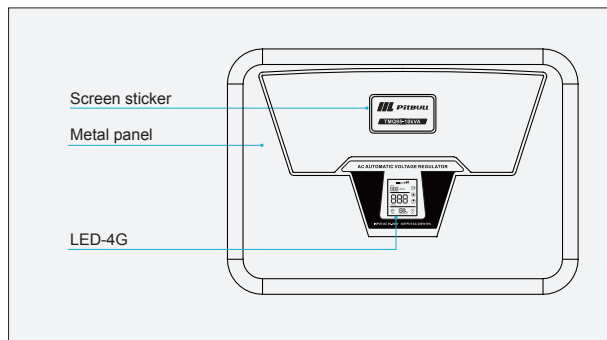

FRONT PANEL

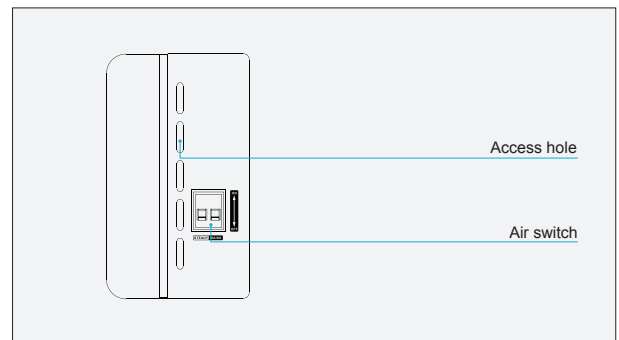

SIDE



Relay Control+Toroidal Transformer, Efficiency > 97%



CLS45/CLS60/CLS95 series (10kVA-12kVA)

PRODUCT FEATURES

The product of this model is a 220V fully automatic voltage regulator, both for desktop and wall mounted. With LED digital display design. It is characterized by stable work, high pressure regulation speed and wide voltage regulation range.

APPLICATION

It is widely used in various industries, small office equipment, refrigerator, electric fan, TV set, computer and other household appliances.

PRODUCTS SPECIFICATION



MODEL	CLS45(10kVA-12kVA)	CLS60(10kVA-12kVA)	CLS95(10kVA-12kVA)
INPUT VOLTAGE	AC 45V-280V	AC 60V-280V	AC 95V-280V
OUTPUT VOLTAGE	AC 220V±10% 50/60Hz		
DELAY TIME	Short Delay:3-5sec Long delay:3-7min		
PROTECTION	Over Voltage(246V±4V),Overload,High Temperature,Short Circuit		
POWER	10000VA	12000VA	
PRODUCT SIZE(CM)	46x32x17.5	46x32x17.5	
PACKING SIZE(CM)	52x38x23.5	52x38x23.5	
PCS/CARTON	1	1	
N.W.(KGS)	22.6	23.3	
G.W.(KGS)	25.2	24.4	

FUNCTION DISPLAY

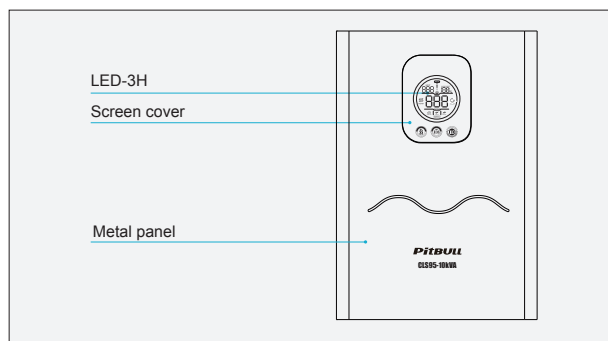

FRONT PANEL

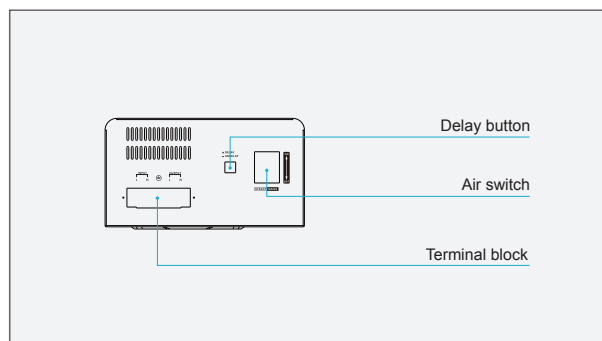

TOP



Light

LCD TV

Rice cooker

Microwave Oven

Printer

Computer

Relay Control+Toroidal Transformer, Efficiency > 97%



CLS45/CLS60/CLS95 series (20kVA-30kVA)

FUNCTION PRESENTATION



MODEL	CLS45(15kVA-20kVA)	CLS60(15kVA-20kVA)	CLS95(15kVA-20kVA)
INPUT VOLTAGE	AC 45V-280V	AC 60V-280V	AC 95V-280V
OUTPUT VOLTAGE	AC 220V±10% 50/60Hz		
DELAY TIME	Short Delay:3-5sec Long delay:3-7min		
PROTECTION	Over Voltage(246V±4V),Overload,High Temperature,Short Circuit		
POWER	15000VA		20000VA
PRODUCT SIZE(CM)	33x31x36		33x31x36
PACKING SIZE(CM)	39x37x46		39x37x46
PCS/CARTON	1		1
N.W.(KGS)	27.7		30.1
G.W.(KGS)	31		33.4

FUNCTION PRESENTATION

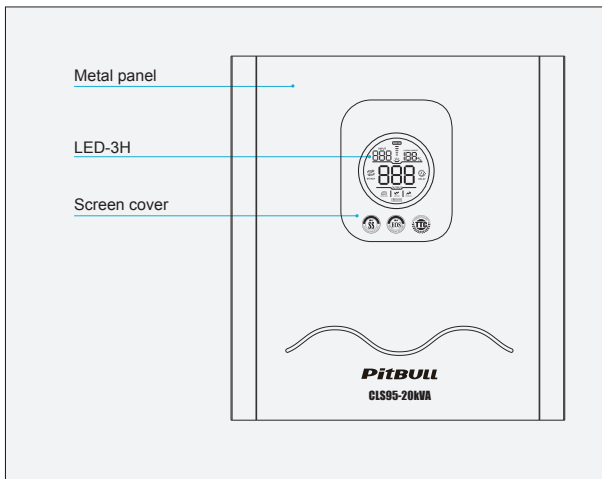

FRONT PANEL

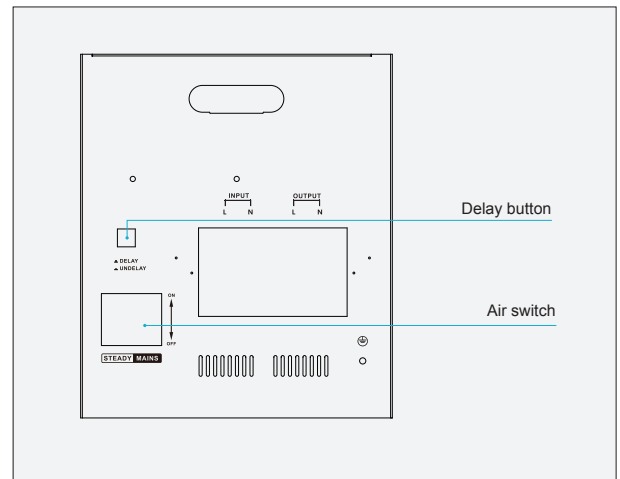

SIDE



Washing Maching Fridge Air Conditioner Air compressor Moto Water pump

Relay Control+Toroidal Transformer, Efficiency >97%

COC95 series (500VA-2000VA)

PRODUCT FEATURES

The product of this model is a 220V fully automatic small-sized voltage regulator, both for desktop and wall mounted. With LED digital display design. It is characterized by small size, light weight, easy to use and install, reliable operation and high pressure regulation speed.

APPLICATION

It is widely used in various industries, small office equipment, refrigerator, electric fan, TV set, computer and other household appliances.

PRODUCTS SPECIFICATION



MODEL	COC95(500VA-2000VA)			
INPUT VOLTAGE	AC 95V-280V			
OUTPUT VOLTAGE	AC 220V±10% 50/60Hz			
DELAY TIME	Short Delay:3-5sec Long delay:3-7min			
PROTECTION	Over Voltage(246V±4V), Overload, High Temperature, Short Circuit			
POWER	500VA	1000VA	1500VA	2000VA
PRODUCT SIZE(CM)	22.5x16x8.5	22.5x16x8.5	28x16x10	28x16x10
PACKING SIZE(CM)	51.5x35x25.5	51.5x35x25.5	51.5x37.5x28.5	51.5x37.5x28.5
PCS/CARTON	6	6	6	6
N.W.(KGS)	12.8	15.6	18.8	23.9
G.W.(KGS)	14.6	16.4	20.6	26.5

FUNCTION DISPLAY

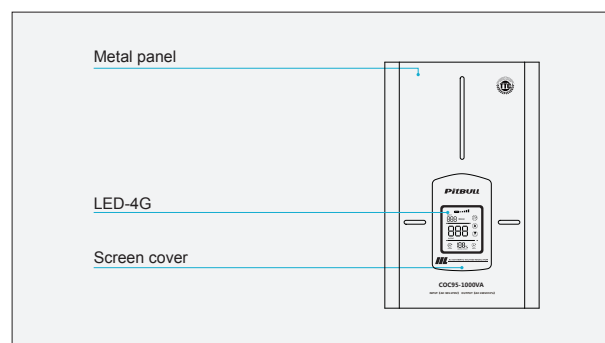

FRONT PANEL

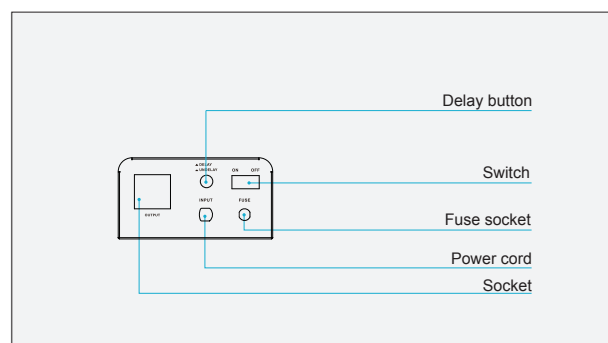

TOP



Relay Control+Toroidal Transformer, Efficiency > 97%

COC/COC45/COC60/COC95 series (3000VA-12kVA)

PRODUCT FEATURES

The product of this model is a 220V fully automatic voltage regulator, both for desktop and wall mounted. With LED digital display design. It is characterized by stable work, high pressure regulation speed and wide voltage regulation range.

PRODUCTS SPECIFICATION



MODEL	COC-3000VA	COC95-3000VA
INPUT VOLTAGE	AC 130V-270V	AC 95V-270V
OUTPUT VOLTAGE	AC 220V±10% 50/60Hz	
DELAY TIME	Short Delay:3-5sec Long Delay:3-7min	
PROTECTION	Over Voltage(246V±4V), Overload, High Temperature, Short Circuit	
POWER	3000VA	3000VA
PRODUCT SIZE(CM)	36x22x12	36x22x12
PACKING SIZE(CM)	41x27x17	41x27x17
PCS/CARTON	1	1
N.W.(KGS)	11.2	12.7
G.W.(KGS)	11.8	13.3



MODEL	COC-5000VA	COC45-5000VA	COC60-5000VA	COC95-5000VA
INPUT VOLTAGE	AC 130V-270V	AC 45V-280V	AC 60V-280V	AC 95V-280V
OUTPUT VOLTAGE	AC 220V±10% 50/60Hz			
DELAY TIME	Short Delay:3-5sec Long Delay:3-7min			
PROTECTION	Over Voltage(246V±4V), Overload, High Temperature, Short Circuit			
POWER	5000VA			
PRODUCT SIZE(CM)	42x29x14			
PACKING SIZE(CM)	47x34x19.5			
PCS/CARTON	1			
N.W.(KGS)	15.7			
G.W.(KGS)	16.3			



Relay Control+Toroidal Transformer, Efficiency > 97%

APPLICATION

It is widely used in various industries, small office equipment, refrigerator, electric fan, computer, pump, air conditioner and other household appliances.

PRODUCTS SPECIFICATION



MODEL	COC(8000VA-12kVA)	COC45(8000VA-12kVA)	COC60(8000VA-12kVA)	COC95(8000VA-12kVA)
INPUT VOLTAGE	AC 130V-270V	AC 45V-280V	AC 60V-280V	AC 95V-280V
OUTPUT VOLTAGE	AC 220V±10% 50/60Hz			
DELAY TIME	Short Delay:3-5sec Long Deley:3-7min			
PROTECTION	Over Voltage(246V±4V),Overload,High Temperature,Short Circuit			
POWER	8000VA	10000VA	12000VA	
PRODUCT SIZE(CM)	46x32x17.5	46x32x17.5	46x32x17.5	
PACKING SIZE(CM)	52x38x23.5	52x38x23.5	52x38x23.5	
PCS/CARTON	1	1	1	
N.W.(KGS)	20	22.6	23.3	
G.W.(KGS)	21.1	25.2	24.4	

FUNCTION DISPLAY

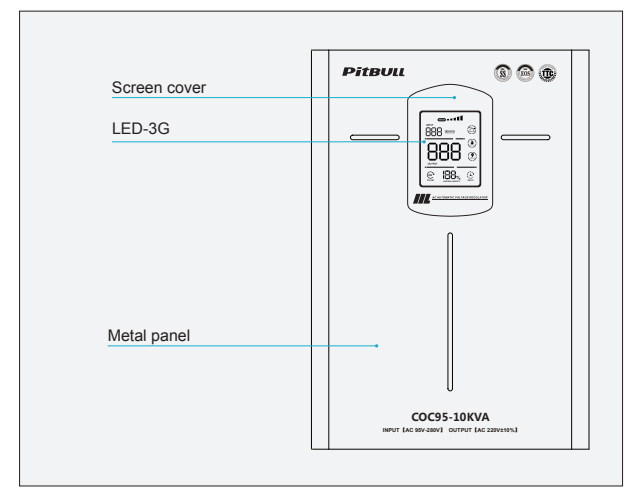

FRONT PANEL

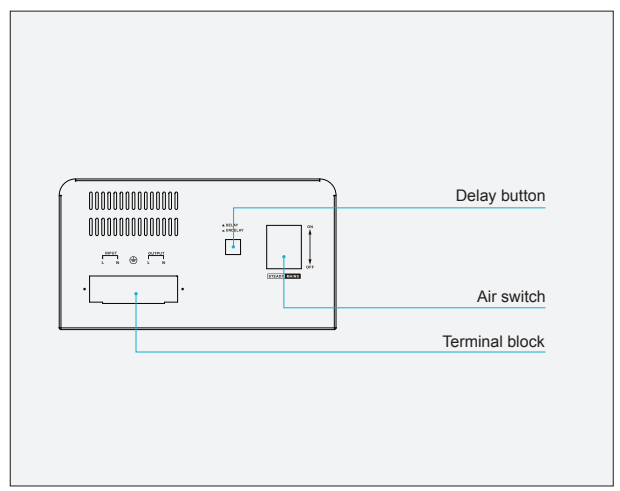

TOP



Relay Control+Toroidal Transformer, Efficiency > 97%

COC/COC45/COC60/COC95 series (15kVA-20kVA)

FUNCTION PRESENTATION



MODEL	COC(15kVA/20kVA)	COC45(15kVA/20kVA)	COC60(15kVA/20kVA)	COC95(15kVA/20kVA)
INPUT VOLTAGE	AC 130V-270V	AC 45V-280V	AC 60V-280V	AC 95V-280V
OUTPUT VOLTAGE	AC 220V±10% 50/60Hz			
DELAY TIME	Short Delay:3-5sec Long Deley:3-7min			
PROTECTION	Over Voltage(246V±4V),Overload,High Temperature,Short Circuit			
POWER	15000VA		20000VA	
PRODUCT SIZE(CM)	30x27x42.5		30x27x42.5	
PACKING SIZE(CM)	40x36.5x51.5		40x36.5x51.5	
PCS/CARTON	1		1	
N.W.(KGS)	30.1		32.5	
G.W.(KGS)	33.4		36.9	

FUNCTION PRESENTATION

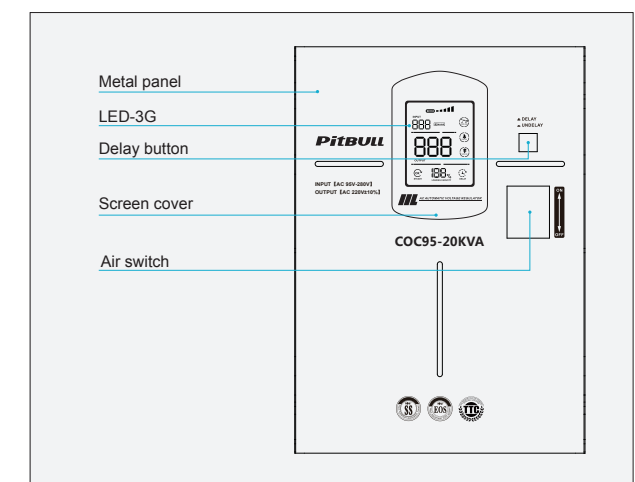

FRONT PANEL

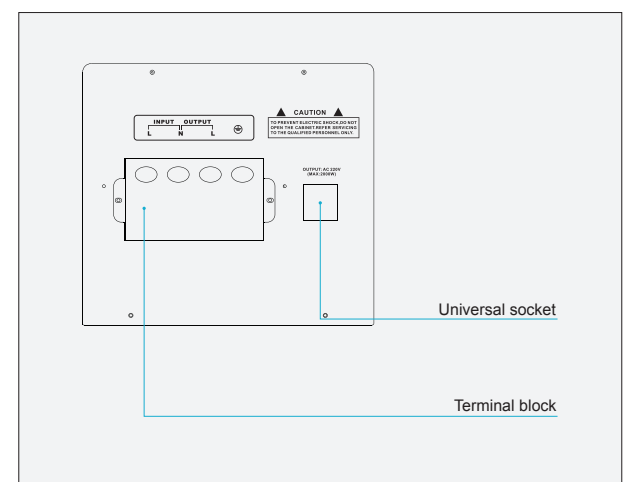

TOP



Relay Control+Toroidal Transformer, Efficiency > 97%



TMN45/TMN60/TMN95 series (3000VA-5000VA)

PRODUCT FEATURES

The product of this model is a 220V fully automatic small-sized voltage regulator, both for desktop and wall mounted. With LED digital display design. It is characterized by small size, light weight, easy to use and install, reliable operation and high pressure regulation speed.

APPLICATION

It is widely used in various industries, small office equipment, refrigerator, electric fan, TV set, computer and other household appliances.

PRODUCTS SPECIFICATION



MODEL	TMN45-3000VA	TMN60-3000VA	TMN95-3000VA
INPUT VOLTAGE	AC 45V-270V	AC 60V-270V	AC 95V-270V
OUTPUT VOLTAGE	AC 220V±10% 50/60Hz		
DELAY TIME	Short Delay:3-5sec Long delay:3-7min		
PROTECTION	Over Voltage(246V±4V),Overload,High Temperature,Short Circuit		
POWER	3000VA	5000VA	
PRODUCT SIZE(CM)	39x24.5x10	39x24.5x10	
PACKING SIZE(CM)	44x29.5x15.3	44x29.5x15.3	
PCS/CARTON	1	1	
N.W.(KGS)	11.3	12.3	
G.W.(KGS)	12	13	

FUNCTION DISPLAY

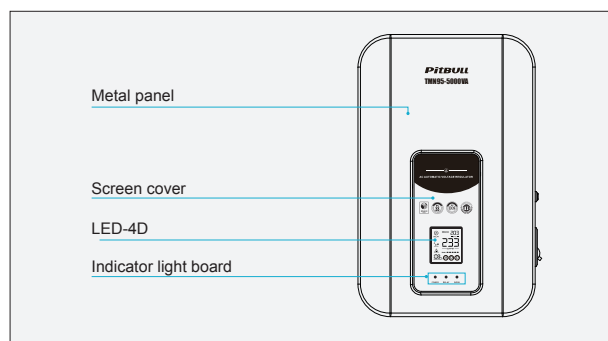

FRONT PANEL

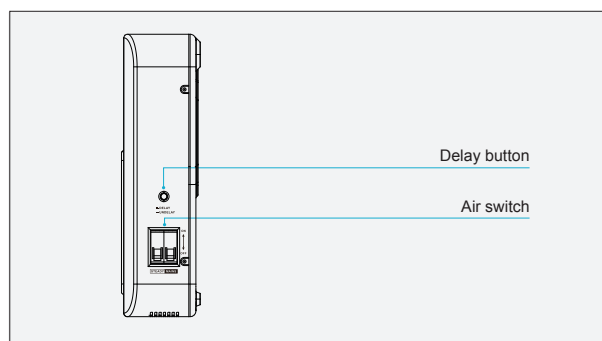

SIDE



Relay Control+Toroidal Transformer, Efficiency > 97%



TMG-A/TMG-A95 series (15kVA-20kVA)

PRODUCT FEATURES

The product of this model is a 220V fully automatic voltage regulator, design of LCD digital display and easy move. It is characterized by stable work, high pressure regulation speed and wide voltage regulation range.

APPLICATION

It is widely used in various industries, small office equipment, refrigerator, electric fan, computer, pump, air conditioner and other household appliances.

PRODUCTS SPECIFICATION



MODEL	TMG-A(15kVA/20kVA)	TMG-A95(15kVA/20kVA)
INPUT VOLTAGE	AC 130V-270V	AC 95V-280V
OUTPUT VOLTAGE	AC 220V±10% 50/60Hz	
DELAY TIME	Short Delay:3-5sec	
PROTECTION	Over Voltage(246V±4V),Overload,High Temperature,Short Circuit	
POWER	15000VA	20000VA
PRODUCT SIZE(CM)	34.5x31.5x57.5	34.5x31.5x57.5
PACKING SIZE(CM)	40.5x37.5x66	40.5x37.3x66
PCS/CARTON	1	1
N.W.(KGS)	30.5	33.5
G.W.(KGS)	36.8	39.7

FUNCTION DISPLAY

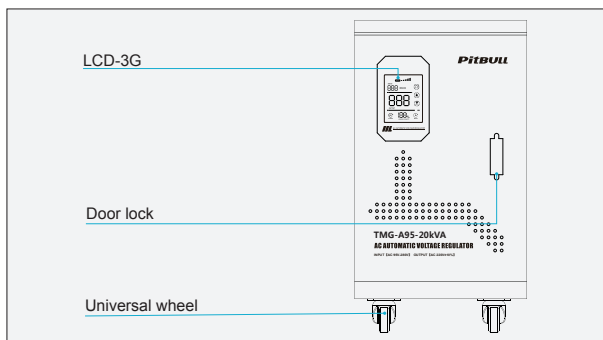

FRONT PANEL

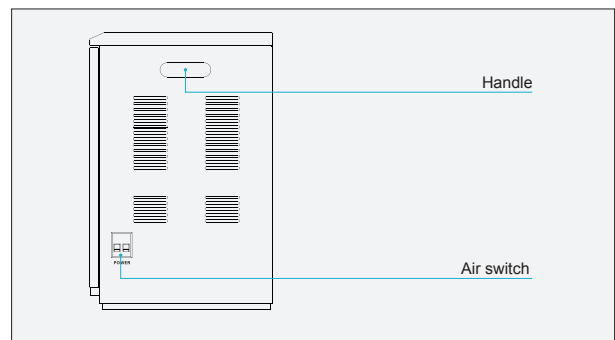

SIDE



Washing Maching Fridge Air Conditioner Air compressor Moto Water pump

Relay Control+Toroidal Transformer, Efficiency >97%

TMS-A45/TMS-A95 series (20kVA-30kVA)

FUNCTION PRESENTATION



MODEL	TMS-A45(20kVA-30kVA)	TMS-A95(20kVA-30kVA)
INPUT VOLTAGE	AC 45V-280V	AC 95V-280V
OUTPUT VOITAGE	AC 220V±10% 50/60Hz	
DELAY TIME	Short Delay:3-5sec Long delay:3-7min	
PROTECTION	Over Voltage(246V±4V),Overload,High Temperature,Short Circuit	
POWER	20kVA	30kVA
PRODUCT SIZE(CM)	37.5x39x39	41.5x45x54
PACKING SIZE(CM)	43.5x45.5x47	47.5x51x66.5
PCS/CARTON	1	1
N.W.(KGS)	36.0	68.4
G.W.(KGS)	42.4	73.2

FUNCTION PRESENTATION

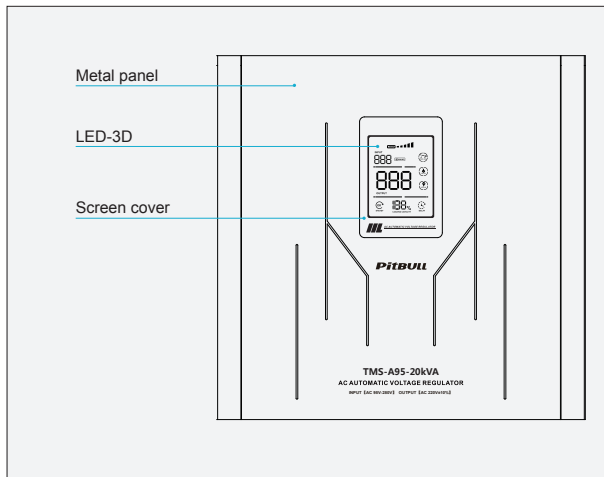

FRONT PANEL

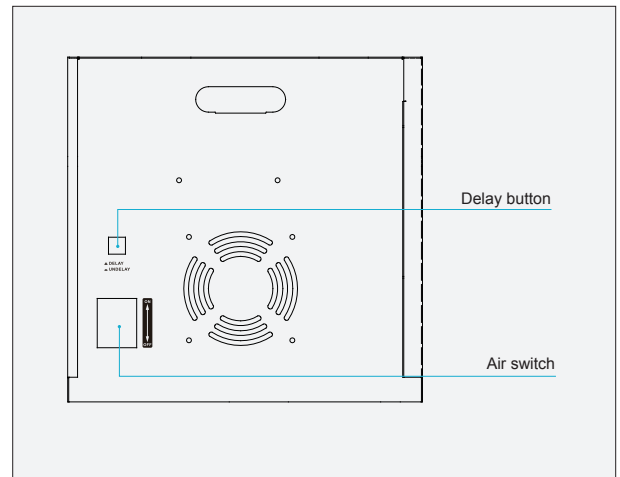

TOP



Light LCD TV Rice cooker Microwave Oven Printer Computer

Relay Control+Toroidal Transformer, Efficiency > 97%



SVC-X series (15kVA)

PRODUCT FEATURES

The product of this model is a high-precision regulator, both for desktop and wall mounted, with LCD digital display design, using motor-driven carbon brush sliding between turns of self-coupling transformer winding and directly adjust the output voltage. It is characterized by high-precision output.

APPLICATION

It is widely used in industrial production, scientific research, health care, household appliances which are with large fluctuation of grid voltage or the area with large seasonal grid voltage. It can provide high-quality power to any load.

PRODUCTS SPECIFICATION



MODEL	SVC-X(15kVA)
INPUT VOLTAGE	AC 100V-260V / 130-250V
OUTPUT VOLTAGE	AC 220V±1~3% 50/60Hz
DELAY TIME	Short Delay:3-5sec
PROTECTION	Over Voltage(246V±4V), Overload, High Temperature, Short Circuit
POWER	15000VA
PRODUCT SIZE(CM)	37.5x39x43.5
PACKING SIZE(CM)	43.5x45.5x51.5
PCS/CARTON	1
N.W.(KGS)	36.0
G.W.(KGS)	42.4

FUNCTION DISPLAY

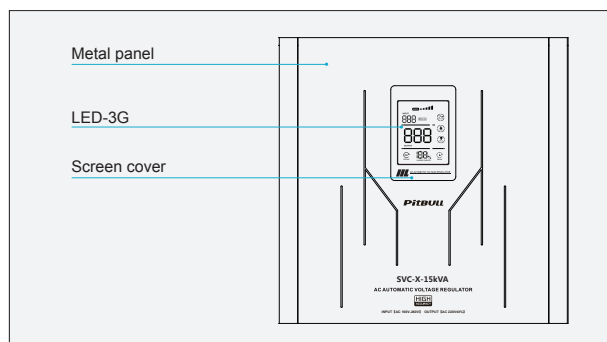

FRONT PANEL

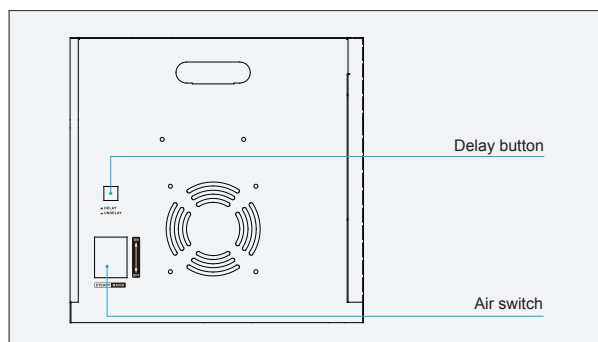

BACK PANEL



Washing Maching

Fridge

Air Conditioner

Air compressor

Moto

Water pump

Relay Control+Toroidal Transformer, Efficiency >97%



TCD-A series (30kVA)

PRODUCT FEATURES

The product of this model is a high-precision regulator, both for desktop and wall mounted, with LCD digital display design, using motor-driven carbon brush sliding between turns of self-coupling transformer winding and directly adjust the output voltage. It is characterized by high-precision output.

APPLICATION

It is widely used in industrial production, scientific research, health care, household appliances which are with large fluctuation of grid voltage or the area with large seasonal grid voltage. It can provide high-quality power to any load.

PRODUCTS SPECIFICATION

MODEL	TCD-A(30kVA)
INPUT VOLTAGE	AC 100V-260V / 130-250V
OUTPUT VOITAGE	AC 220V±1~3% 50/60Hz
DELAY TIME	Short Delay:3-5sec
PROTECTION	Over Voltage(246V±4V),Overload,High Temperature,Short Circuit
POWER	30000VA
PRODUCT SIZE(CM)	40x45x94.7
PACKING SIZE(CM)	51.5x46.5x104
PCS/CARTON	1
N.W.(KGS)	137
G.W.(KGS)	147



FUNCTION DISPLAY

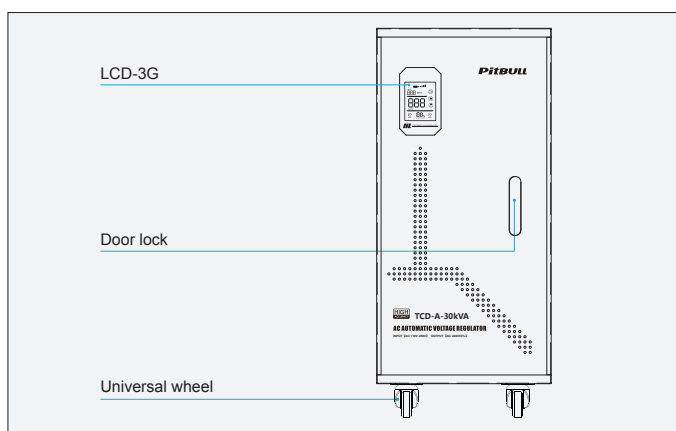

FRONT PANEL



Washing Maching

Fridge

Air Conditioner

Air compressor

Moto

Water pump

Servo Motor Control+Toroidal Transformer, Efficiency > 97%



TND-A series (50kVA)

PRODUCT FEATURES

The product of this model is a high-precision regulator, cabinet type with LED digital display design. It is mainly composed of voltage regulation transformer and compensation transformer and characterized by sufficient power, can achieve relatively large power and maintain high-precision output.

APPLICATION

It is widely used in industrial and mining enterprises, printing, machine tools, post and telecommunications, railways, construction sites, schools, hospitals, hotels, defense, scientific research and other departments of electronic computers, precision machine tools, precision instruments, experimental devices, Elevators and production lines all places where voltage stability is required.

PRODUCTS SPECIFICATION

SINGLE PHASE **HIGH ACCURACY**

MODEL	TND-A(50kVA)
INPUT VOLTAGE	AC 80V-260V / 100V-260V / 130-260V
OUTPUT VOITAGE	AC 220V±1~3% 50/60Hz
DELAY TIME	Short Delay:3-5sec
PROTECTION	Over Voltage(246V±4V),Overload,High Temperature,Short Circuit
POWER	50000VA
PRODUCT SIZE(CM)	55x50x116.5
PACKING SIZE(CM)	61.5x56x123
PCS/CARTON	1
N.W.(KGS)	179
G.W.(KGS)	190



FUNCTION DISPLAY

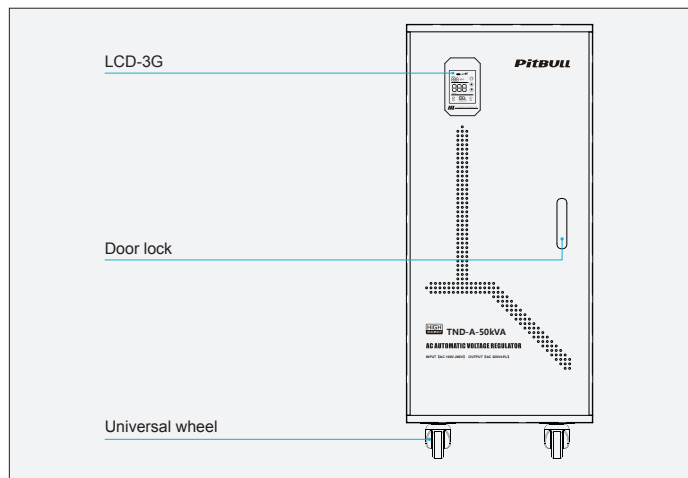

Servo Motor Control+Toroidal Transformer, Efficiency > 97%



TNS-C series (9kVA-30kVA)

PRODUCT FEATURES

The product of this model is a high-precision regulator, cabinet type design. With single phase voltage regulation. Pointer display/Digital display selection.

APPLICATION

It is widely used in industrial and mining enterprises, printing, machine tools, post and telecommunications, railways, construction sites, schools, hospitals, hotels, defense, scientific research and other departments of electronic computers, precision machine tools, precision instruments, experimental devices, Elevators and production lines all places where voltage stability is required.

PRODUCTS SPECIFICATION

THREE PHASE

MODEL	TNS-C(9kVA-15kVA)	
INPUT VOLTAGE	AC 260V-456V	
OUTPUT VOITAGE	AC 380V±1~3% 50/60Hz	
DELAY TIME	Short Delay:3-5sec	
PROTECTION	Over Voltage,Overload,High Temperature,Short Circuit	
POWER	9000VA	15000VA
PRODUCT SIZE(CM)	32x41.5x75.4	33.7x41.5x81.2
PACKING SIZE(CM)	38x46.9x83.9	39.7x47x89.7
PCS/CARTON	1	1
N.W.(KGS)	38.6	48
G.W.(KGS)	43.7	54



Washing Maching



Fridge



Air Conditioner



Air compressor



Moto



Water pump

Servo Motor Control+Toroidal Transformer, Efficiency >97%



PRODUCTS SPECIFICATION



THREE PHASE



MODEL	TNS-C(20kVA-30kVA)	
INPUT VOLTAGE	AC 260V-456V	
OUTPUT VOITAGE	AC 380V±1~3% 50/60Hz	
DELAY TIME	Short Delay:3-5sec	
PROTECTION	Over Voltage,Overload,High Temperature,Short Circuit	
POWER	20000VA	30000VA
PRODUCT SIZE(CM)	37.7x44.7x102	37.7x44.7x102
PACKING SIZE(CM)	43.7x50.1x108.5	43.7x50.1x108.5
PCS/CARTON	1	1
N.W.(KGS)	75	101.5
G.W.(KGS)	83.5	115.5

FUNCTION DISPLAY

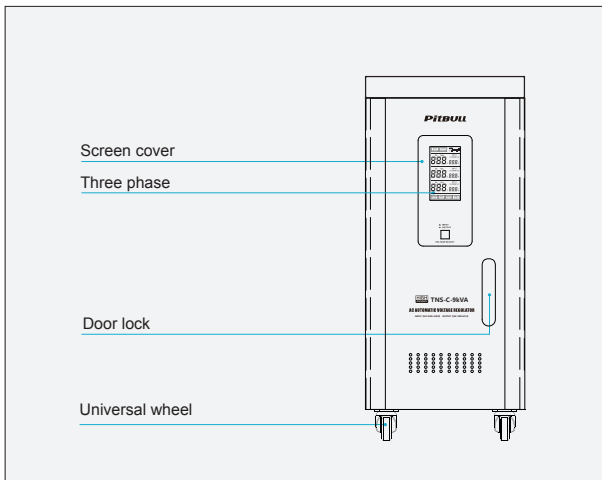

TND-C-9kVA

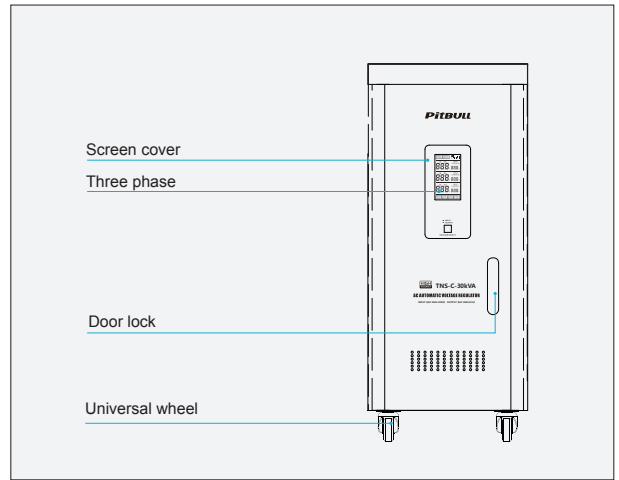

TND-C-30kVA



Washing Maching



Fridge



Air Conditioner



Air compressor



Moto



Water pump

Servo Motor Control+Toroidal Transformer,Efficiency > 97%



TNSB-A series (40kVA-50kVA)

PRODUCT FEATURES

The product of this model is a three phase compensation high-precision regulator, cabinet type with LED digital display design, compensated structure voltage regulation. It is mainly composed of voltage regulation transformer and compensation transformer and characterized by sufficient power, can achieve relatively large power and maintain high-precision output.

APPLICATION

It is widely used in industrial and mining enterprises, printing, machine tools, post and telecommunications, railways, construction sites, schools, hospitals, hotels, defense, scientific research and other departments of electronic computers, precision machine tools, precision instruments, experimental devices, Elevators and production lines all places where voltage stability is required.

PRODUCTS SPECIFICATION



THREE PHASE



MODEL	TNSB-A(40kVA)
INPUT VOLTAGE	AC 260V-456V
OUTPUT VOITAGE	AC 380V±1~3% 50/60Hz
DELAY TIME	Short Delay:3-5sec
PROTECTION	Over Voltage, Overload, High Temperature, Short Circuit
POWER	40000VA
PRODUCT SIZE(CM)	59.5x49x111
PACKING SIZE(CM)	66x55.5x134
PCS/CARTON	1
N.W.(KGS)	170
G.W.(KGS)	183



Washing Maching



Fridge



Air Conditioner



Air compressor



Moto



Water pump

Servo Motor Control+Toroidal Transformer, Efficiency >97%



PRODUCTS SPECIFICATION



THREE PHASE **HIGH ACCURACY**

MODEL	TNSB-A(50kVA)
INPUT VOLTAGE	AC 260V-456V
OUTPUT VOITAGE	AC 380V±1~3% 50/60Hz
DELAY TIME	Short Delay:3-5sec
PROTECTION	Over Voltage,Overload,High Temperature,Short Circuit
POWER	50000VA
PRODUCT SIZE(CM)	75x63x136
PACKING SIZE(CM)	84.5x72.5x144
PCS/CARTON	1
N.W.(KGS)	190
G.W.(KGS)	203

FUNCTION DISPLAY

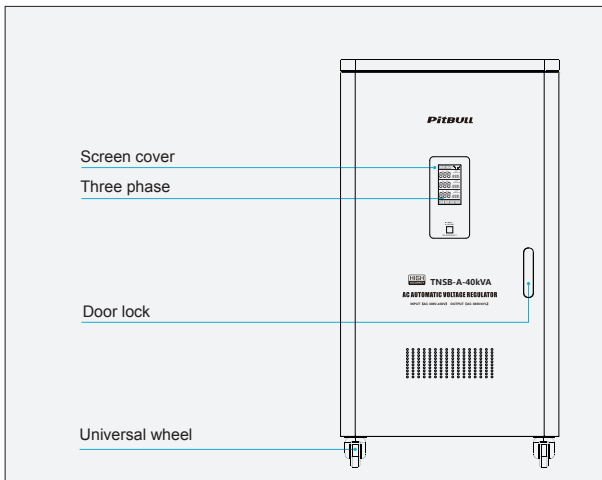

TNSB-A-40kVA

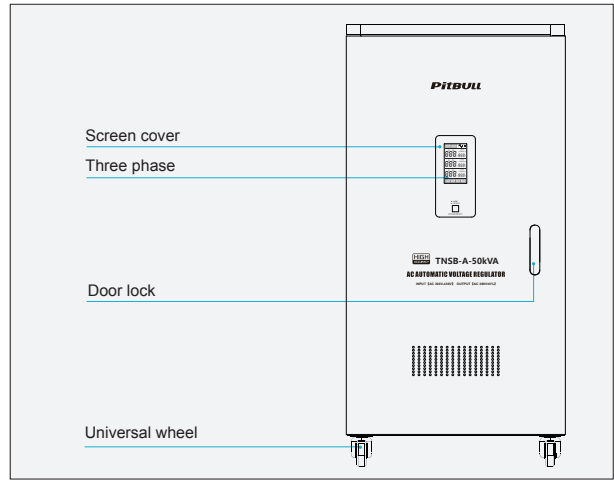

TNSB-A-50kVA



Washing Maching



Fridge



Air Conditioner



Air compressor



Moto



Water pump

Servo Motor Control+Toroidal Transformer,Efficiency > 97%